

MOEN® 摩恩

Specifications 规格书

产品描述

- 不锈钢沥水篮
- 产品规格: L:420/480 × W:250 × H:100(mm)

标准

- 符合Q/MESN 4-2022

质保期

- 1年有限保修, 人为损坏和化学品侵蚀除外

DESCRIPTION

- Stainless steel drain basket
- Product specifications: L:420/480 × W:250 × H:100(mm)

STANDARD

- Comply with Q/MESN 4-2022

WARRANTY

- 1 year limited warranty except artificial damage and chemicals erosion

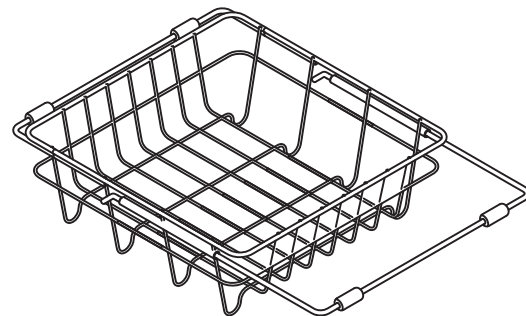

沥水篮

Drain Basket

型号: SKA12 系列

MODELS: SKA12 series

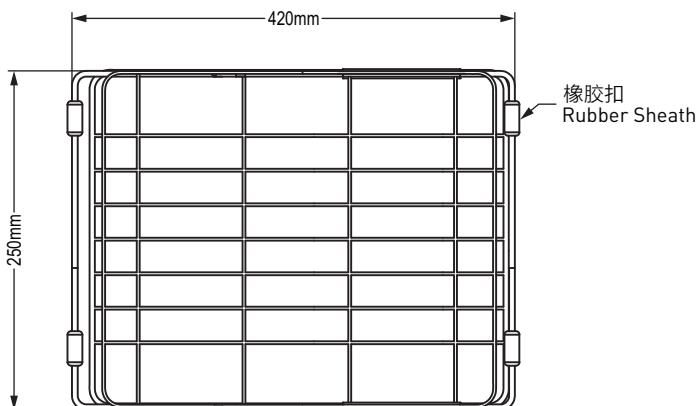
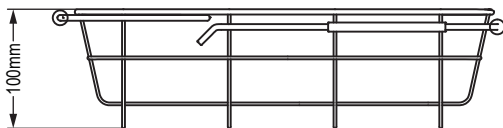

收缩 Contractility

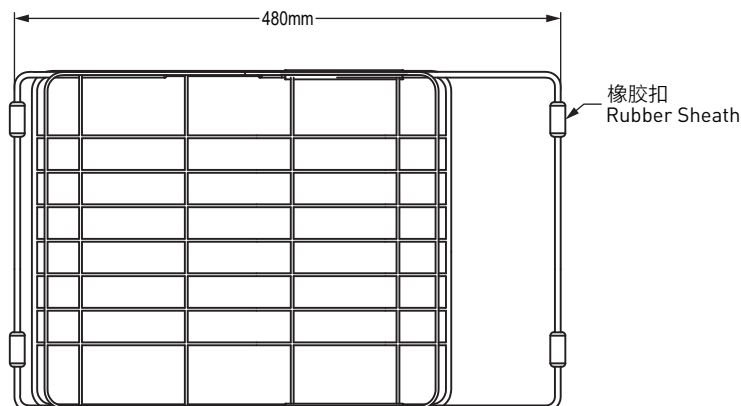

打开 Open

CRITICAL DIMENSIONS DO NOT SCALE